



# FILTRI JOLLY 30-40



# FILTRI JOLLY 30-40

**ITA** I Filtri Jolly sono costruiti interamente all'interno della nostra officina e il progetto risale al 1980. Sono studiati per poter sgrossare, brillantare e sterilizzare vini, olii, birra, succhi di frutta e altri liquidi alimentari. Sono dotati della valvola di regolazione di flusso con manometro e assaggiavino.

**ING** Jolly filters are fully designed and manufactured in our workshop. The project dates back 1980. They are designed to refine, clarify, and sterilise wines, oils, beer, fruit juices and food liquids of various types. They are fitted with a valve for flow regulation with gauge and wine-tasting tap.

## OPTIONALS

Piastra doppia filtrazione/Double filtration plate  
Bypass

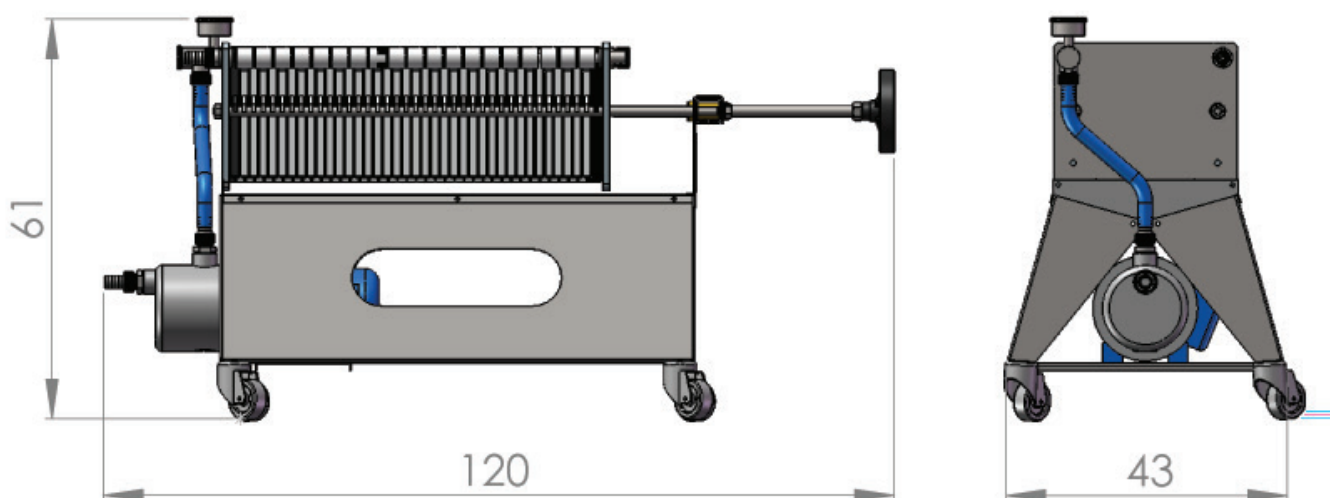

## CARATTERISTICHE TECNICHE TECHNICAL FEATURES

	JOLLY 30	JOLLY 40
PRODUZIONE OLIO (Lt/h) OIL PRODUCTION (Lt./h)	150	200
PRODUZIONE VINO (Lt/h) WINE PRODUCTION (Lt./h)	900	1200
N° PIASTRE N° OF PLATES	31	41
SUPERFICIE FILTRANTE (mq) FILTERING SURFACE (mq)	1,2	1,6
PESO (Kg) WEIGHT (Kg)	43	46